



51-201006 - YA-WOLVERINE-SDK01

Instructions for Installation and Care of Yamaha Wolverine Soft Door Kit

Notice: Do not smoke inside the cab or expose the enclosure to direct flames. Cab is Flammable.

1. Be sure to read these instructions thoroughly before opening and installing the Yamaha Soft Door Kit. The installation is best done when the temperature is 70 degrees F. or warmer. The temperature affects the adhesive Velcro, if conditions prevent installing in warmer weather it helps to store the adhesive Velcro at room temperature prior to installation.
2. Carefully open the carton and remove the enclosure on a large flat surface that is clean and free of dirt.
3. Check over the parts included in the carton with the parts list shown below:

<u>Adhesive Velcro Hook Strips Qty</u>	<u>Length</u>
14	3"
2	10"
2	40"
Snap Screw Studs	9 each (1 extra)

1. Begin by taking the 40" adhesive Velcro strip and run it up the back of the roll cage facing towards the rear of the vehicle. You will see three double-sided Velcro tabs sewn along the back of the doors. Begin installing the adhesive Velcro from the bottom of the roll cage and work your way up the bar. See photo below.



2. Take the Velcro tabs sewn along the back edge of the door and attach it to the 40" adhesive strip on the frame. Begin at the bottom and work your way up. This will place the door in the proper location.
3. Next attach the double-sided Velcro strips sewn perpendicular to the edge of the door. At each of the double-sided strips take one of the 3" adhesive Velcro strips and adhere it to the inside of the frame. Then wrap the double-sided strip around it so that the adhesive strip holds it firmly in place. the following diagrams shows how it should look.

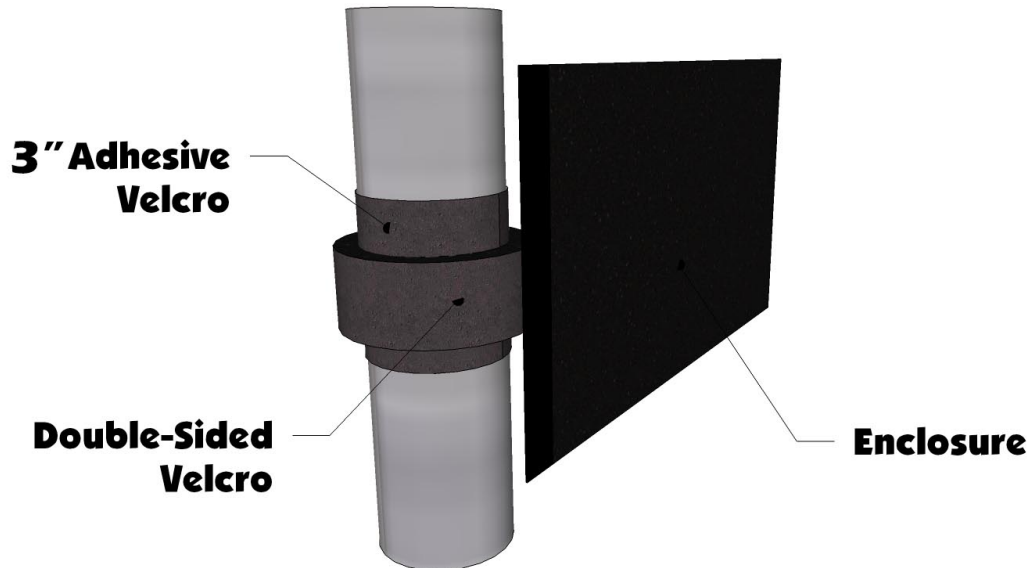
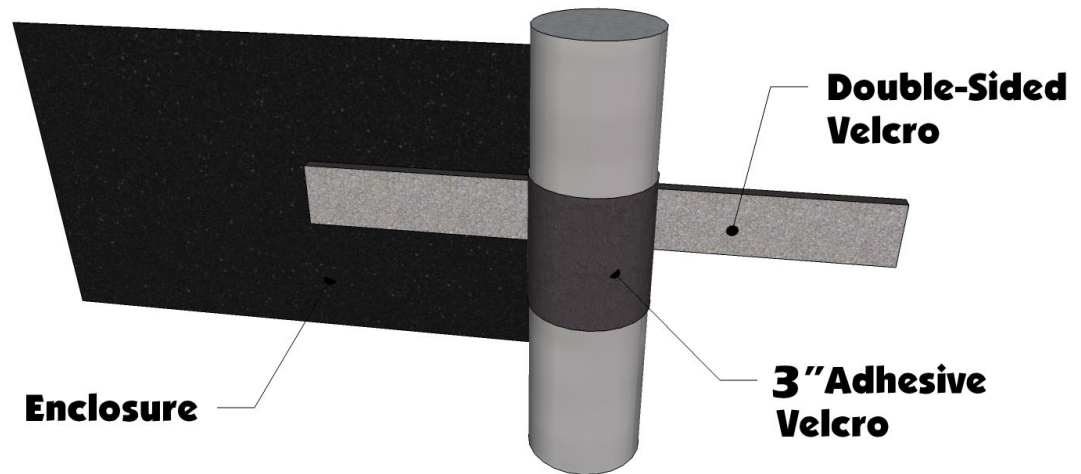

4. Then place the 10” adhesive Velcro strip at the bottom of the front wing window as shown in the photo below.



5. Once all the Velcro is in place the last thing to do is install the screw snap studs. Three go on the outside of the vehicle and one goes on the inside of the door.

NOTE: The best way to install the snap studs is to put them in the button sockets in the door first. Then push them into the plastic to make an indentation. Then pull the screw stud out and screw it into the plastic where the mark was made. See Photos Below.

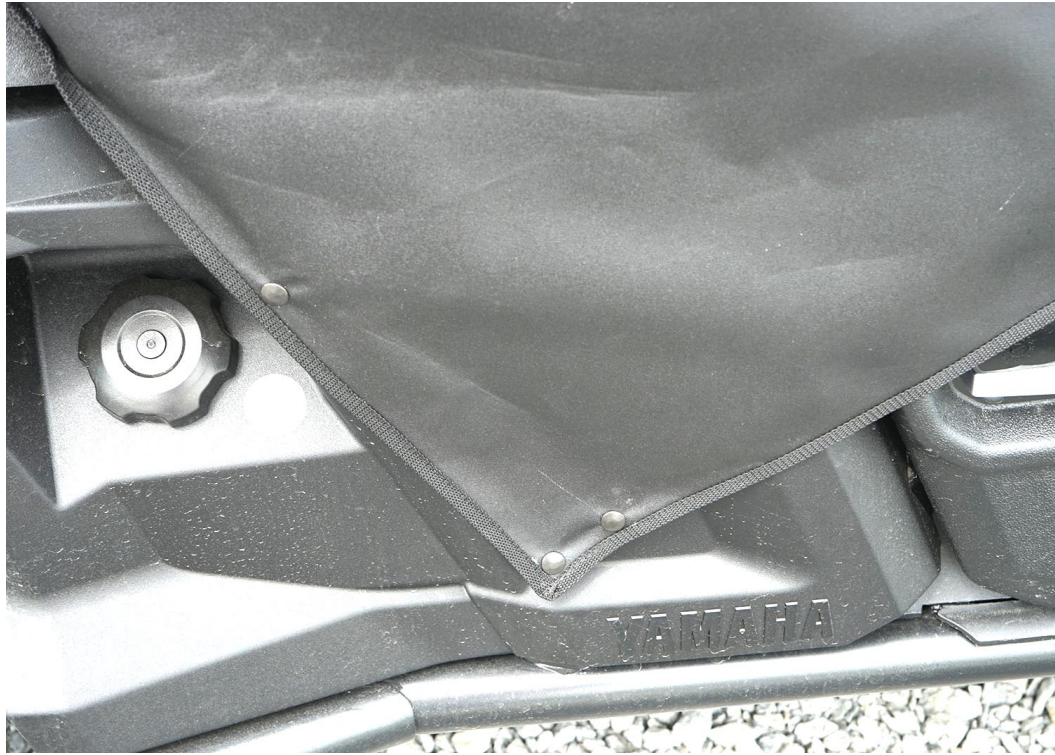

Cleaning and Storage Recommendations:

1. Before removing the Cab for storage, make sure it is very clean in order to prevent scratching of the window panels. Clean with a soft rag or sponge using a mild liquid detergent soap and warm water solution. Never rub the windows with a dry cloth or rag! Let the Cab dry thoroughly before attempting to roll for storage.
2. It is important that the Cab be rolled up for storage rather than folding. Folding will cause damage to the windows!!! Carefully roll up the Cab like the way it was when it was packed at the factory on a large, clean and flat surface, fold the doors over the rear panel first, then, interleave the top and windshield on top of the doors. Begin rolling the Cab into a roll approximately 8 inches in diameter. Put the rolled Cab back into the carton for storage at a normal room temperature. It is best not to expose the Cab to either extreme hot or cold temperatures when storing.

If you have any questions, comments, need assistance, or are missing parts, please contact us by one of the methods below.

 service@seizmik.com

 **1-866-838-3366**
between 9:00 AM and 5:00 PM EST.



www.seizmik.com/customer-support



WARNING: This product contains a chemical known to the State of California to cause cancer. For more information, go to www.P65Warnings.ca.gov