



**Part Number - 51-20994**

### **Installation and Care for Can-Am Maverick X3 (4Door) Soft Door Kit**

Caution: Do not smoke inside the cab or expose the enclosure to direct flames. Cab Material is Flammable.

Be sure to read these instructions thoroughly before opening and installing the enclosure. The installation is best done when the temperature is 70 degrees F or warmer. The temperature affects the adhesive Velcro, if conditions prevent installing in warmer weather; store the adhesive Velcro at room temperature prior to installation.

1. Carefully open the carton and remove the enclosure on a large flat surface that is clean and free of dirt.
2. Check the parts included in the carton with the parts list shown below:

#### **Included Parts:**

2" Adhesive Backed Hook Velcro  
26 each    3 inches  
2 each    6 inches

**Snap Studs** - 40 each (2 extra)

**Door Panels** - 4 each

**Note:** Loosening or even removing a previously installed windshield or top will make installation much easier.

#### **Tools Needed for Installation:**

Phillips Screwdriver or Electric Screwdriver with Phillips bit. **Note: If using an electric screwdriver, set torque to a low setting to avoid overtightening while installing the snap studs. This can damage the body panels.**

3. Begin by holding the front door up to the frame and attach it using the double-sided Velcro strips sewn onto the edge of the door. The edge of the door should be about 1/2in above the center line of the frame. Clean the area near each of the double-sided Velcro straps. At location of each double-sided strip, take one of the 3" adhesive Velcro strips and adhere it to the inside of the frame. Then wrap the double-sided strip around it so that the adhesive strip holds it firmly in place. The following diagrams show how it should look.

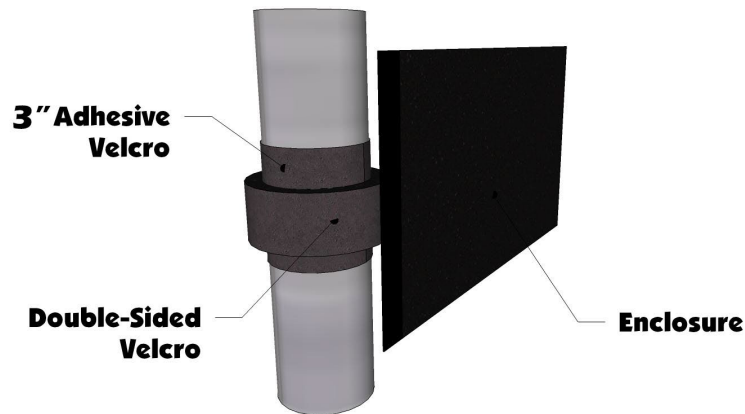
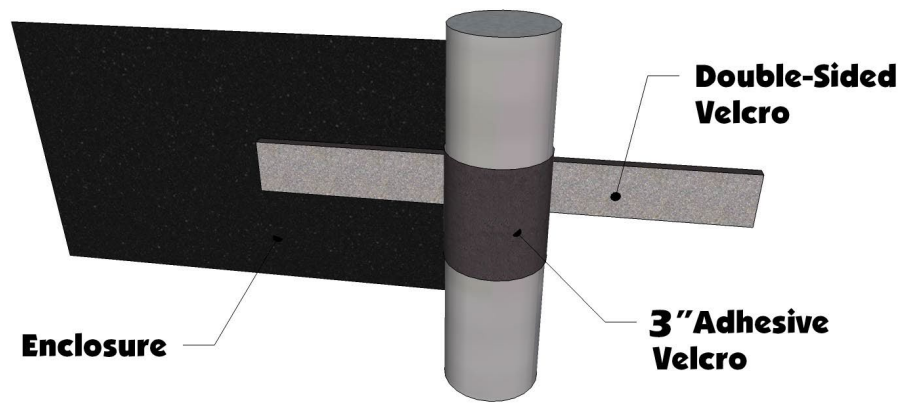

4. Next install the threaded snap studs into the body at the location of each snap. It is best to work from the front to the rear of the unit when installing the snap studs. The following image shows the location of each snap.



Begin installation of the rear door following the same procedure used to install the front door. Hold the door up to the frame and apply the adhesive hook Velcro strips at the locations of the double-sided Velcro strips. The front double sided strip will use the same adhesive hook Velcro location as the back mounting point of the front door. There is also a strip of Velcro that runs vertically that is used to seal the two doors together. Some time needs to be taken to ensure the two doors fit together properly while also ensuring the back section of the rear door follows the profile of the back section of the frame. Extra pieces of adhesive Velcro are provided in case one or more need to be moved during installation.

5. Once the rear door is attached to the frame using the double-sided Velcro, you will need to install the snap studs into the body of the unit. This time working from the back to the front is advised. Care needs to be taken to follow the contours of the rear section of the body to get the proper fitment. The following image shows the location of the snap studs on a completed install.



6. Complete the installation by applying the 5in section of adhesive hook Velcro to the top, back portion of the door.

## Cleaning and Storage Recommendations:

1. Before removing the Cab for storage, make sure it is very clean to prevent scratching of the window panels. Clean with a soft rag or sponge using a mild liquid detergent soap and warm water solution. Never rub the windows with a dry cloth or rag! Let the Cab dry thoroughly before attempting to roll for storage.
2. It is important that the Cab be rolled up for storage rather than folding. Folding will cause damage to the windows!!! Carefully roll up the Cab like the way it was when it was packed at the factory. On a large, clean, and flat surface, fold the doors over the rear panel first, then, interleave the top and windshield on top of the doors. Begin rolling the Cab into a roll approximately 8 inches in diameter. Put the rolled Cab back into the carton for storage at a normal room temperature. It is best not to expose the Cab to either extreme hot or cold temperatures when storing.

If you have any questions, comments, need assistance, or are missing parts, please contact us by one of the methods below.

If you have any questions, comments, need assistance, or are missing parts, please contact us by one of the methods below.

 [service@seizmik.com](mailto:service@seizmik.com)

 **1-866-838-3366**  
between 9:00 AM and 5:00 PM EST.



[www.seizmik.com/customer-support](http://www.seizmik.com/customer-support)



**WARNING:** This product contains a chemical known to the State of California to cause cancer. For more information, go to [www.P65Warnings.ca.gov](http://www.P65Warnings.ca.gov).