

Installation & Operations Manual Polaris RS1 Vented Windshield

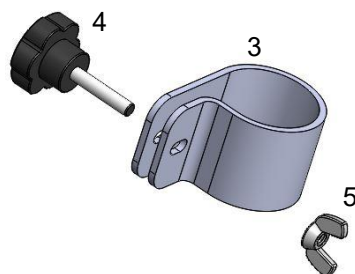

Kit Contents:	Qty
1) Windshield Assembly with vents	1
2) Gasket	1
3) 1.75 P Clamp	4
4) Threaded Knob	4
5) Wing Nut	4

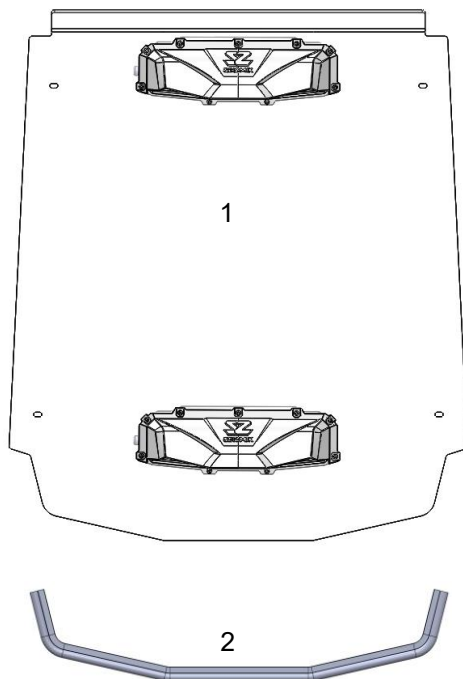

Installation Information:

This product does not require any modifications to your vehicle. Please familiarize yourself with all the steps before beginning assembly.

Compatibility Info:

This windshield is designed to work with other Seizmik branded Accessories for the Polaris RS1 as well as OEM Polaris hard tops. Please note Seizmik cannot guarantee fitment with other branded aftermarket products. Please research installation details on our products and others when trying to combine different branded accessories.

Seizmik makes Windshields, Mirrors, Door Kits, Light Bars, Hood Racks, and other great accessories for UTV's to maximize the vehicles usefulness. To help you do what you do better.

If you have any questions, comments, need assistance, or are missing parts, please visit our website <http://seizmik.com/customer-support> Or email us at service@seizmik.com. Visit www.seizmik.com for more information on our product or call 1-866-838-3366 between 9:00AM and 5:00PM EST.

Windshield Installation:

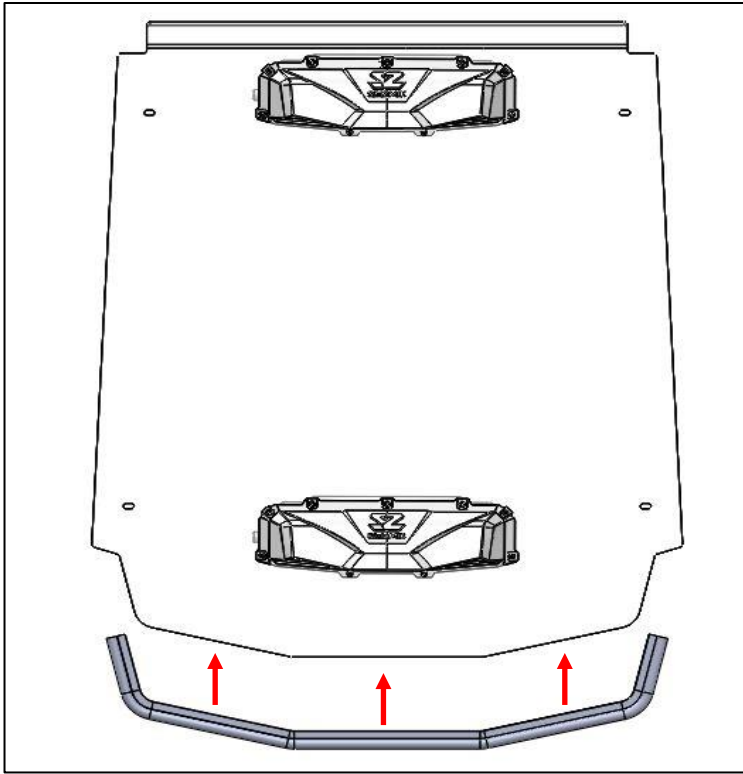

1. Push gasket onto lower windshield

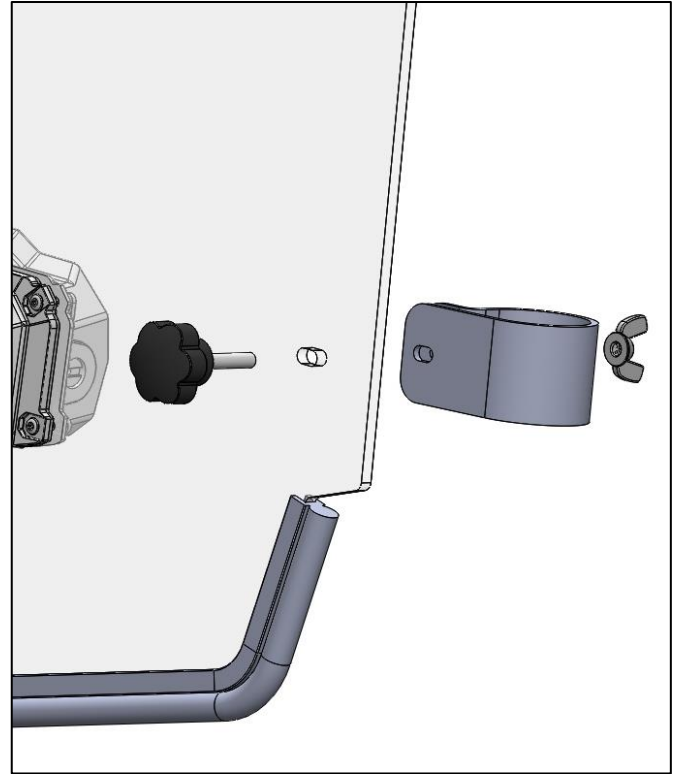

2. Snap 4 P Clamps onto the roll cage in the approximate locations of the mounting holes in the windshield. Mount windshield with the 4 threaded knobs and wing nuts. Move windshield around as necessary for alignment before fully tightening.

VENT OPERATION:

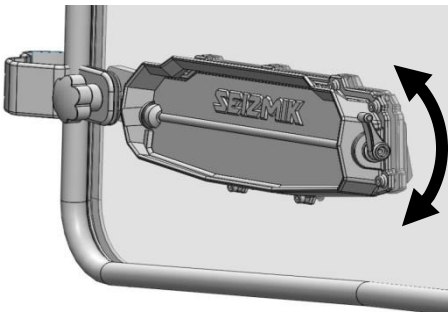

Turn handle to adjust vent. If the vent seems too tight or too loose, it can be adjusted by turning the T10 Torx screw in the handle.

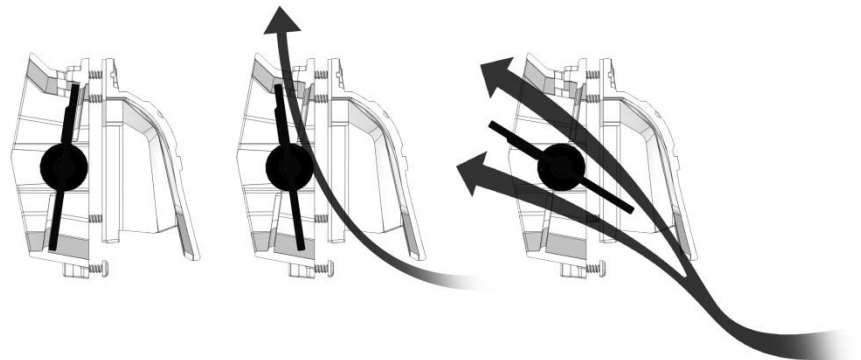

The vent has 3 positions: Closed, Defog, and open.

Windshield Installation:

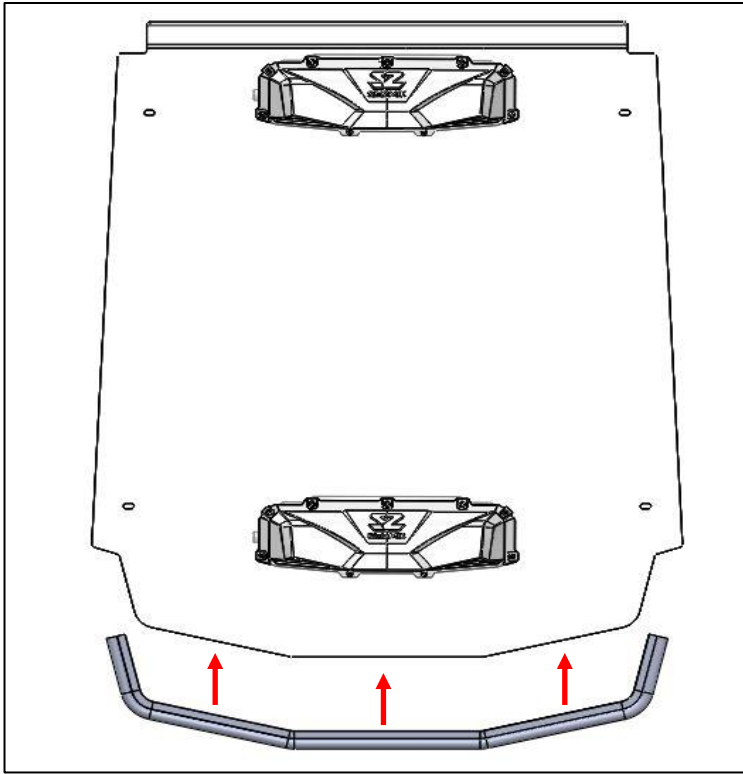

1. Push gasket onto lower windshield

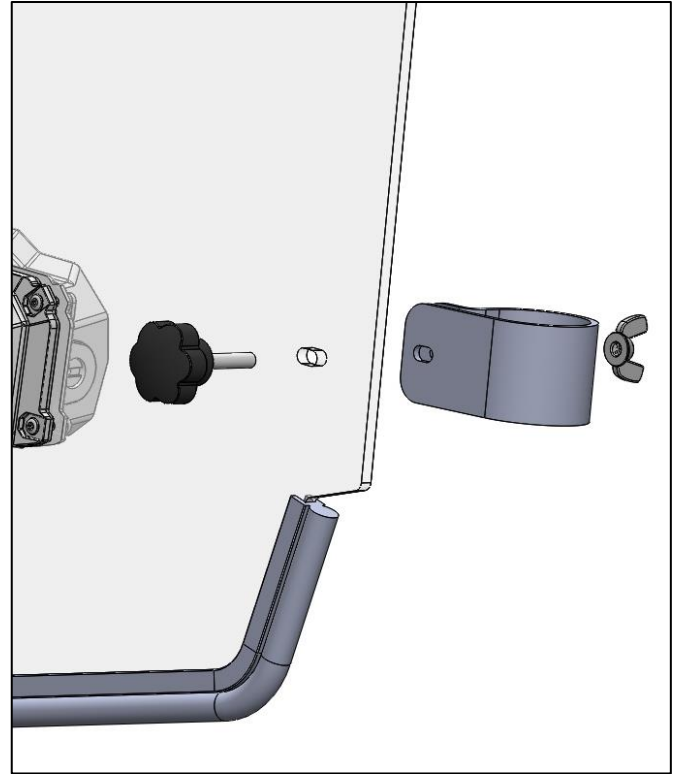

2. Snap 4 P Clamps onto the roll cage in the approximate locations of the mounting holes in the windshield. Mount windshield with the 4 threaded knobs and wing nuts. Move windshield around as necessary for alignment before fully tightening.

VENT OPERATION:

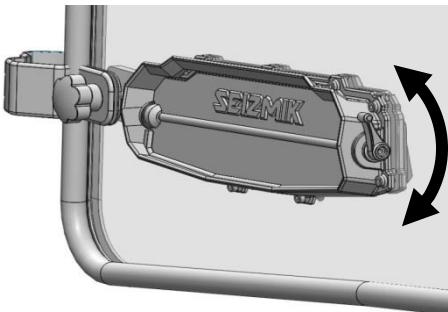

Turn handle to adjust vent. If the vent seems too tight or too loose, it can be adjusted by turning the T10 Torx screw in the handle.

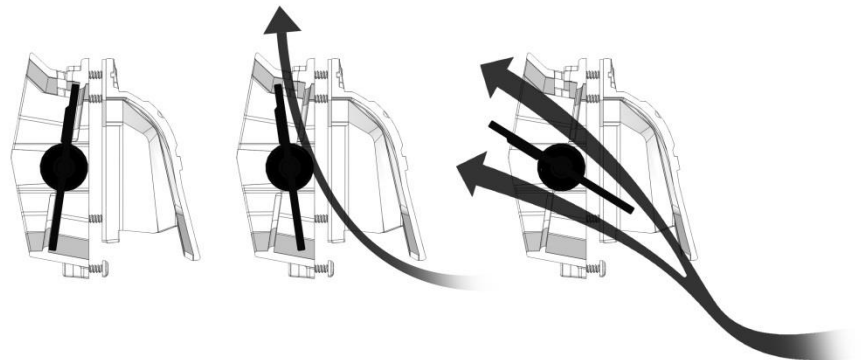

The vent has 3 positions: Closed, Defog, and open.



APPENDIX

Versa Vent Polaris RS1 (26096)		
Item #	Part#	Description
1	54 SW-90680	Double sided hardcoated polycarbonate panel (26096)
2	54 SW-90681	Gasket
3	54 SW-90246	1.75" plastic P clamp
4	54-90042	VERSA KNOB WITH WING NUT FOR WINDSHIELDS
5	x	Wing Nut
	54 SW-90156	Vent/scoop
	54 SW-90157	Louver Assembly
	54 SW-90158	Vent gasket
	54 SW-90159	6-20 x .75 screw

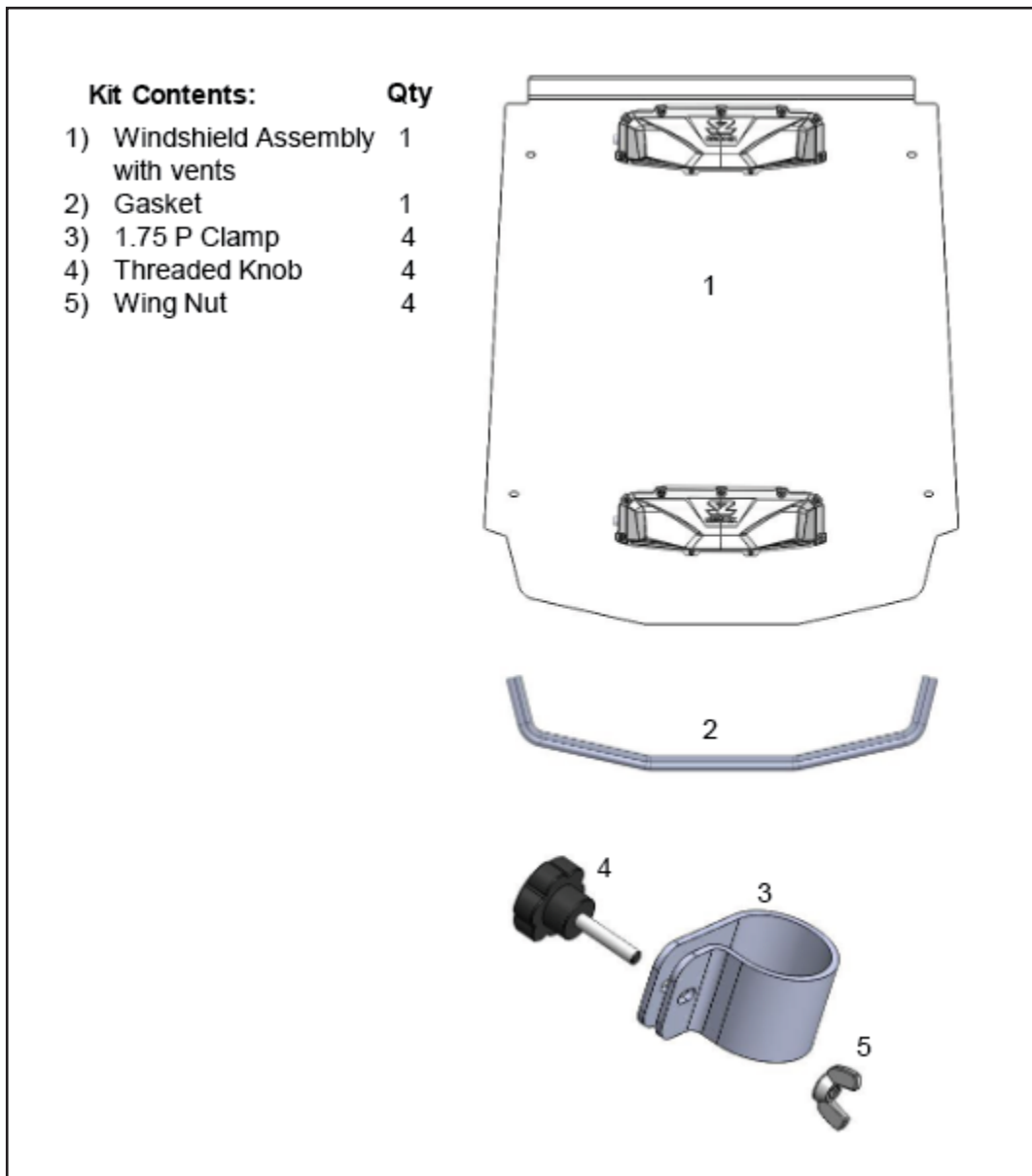



APPENDIX

Versa Vent Polaris RS1 (26096)		
Item #	Part#	Description
1	54 SW-90680	Double sided hardcoated polycarbonate panel (26096)
2	54 SW-90681	Gasket
3	54 SW-90246	1.75" plastic P clamp
4	54-90042	VERSA KNOB WITH WING NUT FOR WINDSHIELDS
5	x	Wing Nut
	54 SW-90156	Vent/scoop
	54 SW-90157	Louver Assembly
	54 SW-90158	Vent gasket
	54 SW-90159	6-20 x .75 screw

