

HDIFFA-RNGXD

Polaris Ranger 1500 XD Front Forward APEX Kit



HL

HIGHLIFTER

SEIZMIK™

**FALCON RIDGE**

 **SNORKEL
YOUR ATV**

SYSTEM 3
OFF-ROAD
Traction. Strength. Style.

EPI
PERFORMANCE

 sales@highlifter.com

 800-699-0947 | 800am - 5 00pm CST

 7455 Atkinson Drive, Shreveport, LA 71129



www.highlifter.com

Parts Available For These Popular Brands and Others

POLARIS

can-am



HONDA

Kawasaki



YAMAHA

Product Disclaimer

The installation of products sold or manufactured by High Lifter Products including, but not limited to suspension components such as lift kits, gear reduction lifts, frame stiffener kits, snorkels, and tires that exceed the original specifications for the vehicle, may change the vehicle's center of gravity and handling characteristics both on- and off-road. You are aware that the installation of tires that are larger than original vehicle specifications may reduce the effectiveness of the braking system. Use of these products may place added stress to the original factory vehicle components which could cause them to weaken or possibly fail.

Products sold or manufactured by High Lifter Products are intended for off-road use only. Operation of a vehicle modified with these products on a road could result in serious bodily injury or death, and such operation may violate the laws of your state or municipality. You agree to operate your vehicle exclusively in the manner intended by the vehicle manufacturer. You agree that failure to safely and reasonably operate your vehicle could result in serious bodily injury or death, and that, as a result of installation of this product(s) to your vehicle, extreme care must be taken to prevent vehicle rollover or loss of control, which may be more likely to occur as a result of said modifications. You will avoid unsafe maneuvers, including sudden sharp turns or other abrupt maneuvers, which could make a vehicular accident more likely. You understand that High Lifter Product is not responsible or liable for any damages or any injuries to yourself or your passengers that could occur upon possible accidents due to driver error, incorrect installations, bad judgment, incompatibility with other aftermarket accessories or natural disasters to the fullest extent allowable by law.

You will have all vehicle occupants fasten seatbelts, if equipped, and wear proper safety equipment, such as DOT approved helmet and eye protection prior to operating the vehicle. You understand and acknowledge that failure to wear proper safety equipment may increase the risk of serious bodily injury or death to yourself and any passengers.

Proper installation of products sold or manufactured by High Lifter Products requires knowledge of the factory recommended procedures for removal and installation of original equipment components. Installation of these products without proper knowledge and experience may affect the performance of these components and the safety of the vehicle and cause serious bodily injury or death. It is strongly recommended that a certified mechanic familiar with the installation of similar components perform the product(s) installation.

Prior to installing any products sold or manufactured by High Lifter Products, you will perform or cause to be performed an inspection of their vehicle to confirm its condition is suitable for the installation of these products. A proper inspection of the vehicle includes confirmation that the vehicle has not been in a collision and is free of corrosion. If the vehicle is suspected to have been in a collision or misused, or is otherwise unsuitable for modification, you will not install the product(s). You will continue to inspect the vehicle prior to each use to confirm its condition is suitable for its intended use, and you acknowledge that the failure to do so may result in serious bodily injury or death, as well as damage to the vehicle itself.

You will install any warning labels provided with the product so it may be prominently seen by yourself and all passengers. You will notify all passengers of the modifications performed to your vehicle prior to operation.

Insurance companies may handle coverage of a modified vehicle differently. Please check with your insurance carrier prior to modifying the vehicle to ensure your coverage remains sufficient.

Installation of this product(s) may void your vehicle warranty. If this is a concern, please check with the manufacturer or dealer before purchase or installation of this product(s).

FRONT UPPER & LOWER ARMS

Front Upper Control Arm

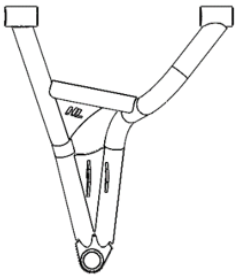

Left 1ea (79-16801-L)

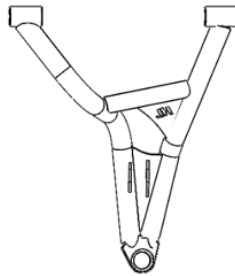

Right 1ea (79-16801-R)

Front Lower Control Arm

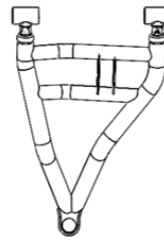

Left 1ea (79-16793-L)

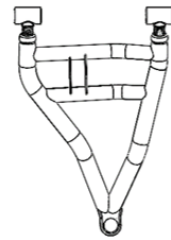

Right 1ea (79-16793-R)



Adjustable
Collar 4ea
(79-10099)



Steering Stop
(2ea) 10U



Brake Line
Clamp 1pk
(79-14813)

1



FRONT PASSENGER SIDE

KEEP ALL FACTORY HARDWARE.

Place jack under the FRONT center of the UTV and lift until the weight is off the suspension. Ensure that the vehicle is properly secured, so that it is stable on the jack.

Remove the front wheels.

2



You will need to remove the nut and bolt that holds the clamps to the brake lines and arm.

then remove the brake calipers and set them aside.

Remove the brake drum, cotter pin, axle nut, and washers from the hub assembly. **YOU WILL REUSE THE FACTORY HARDWARE** to reconnect the new control arms to the frame.

3

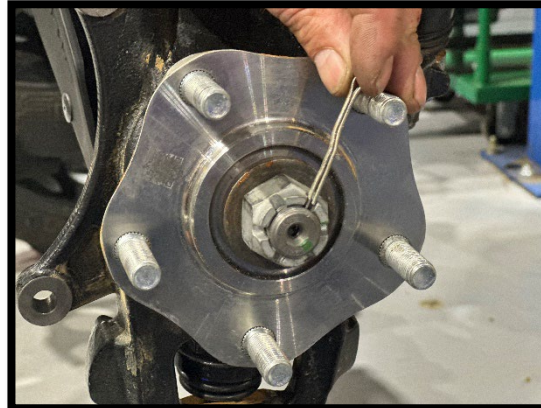
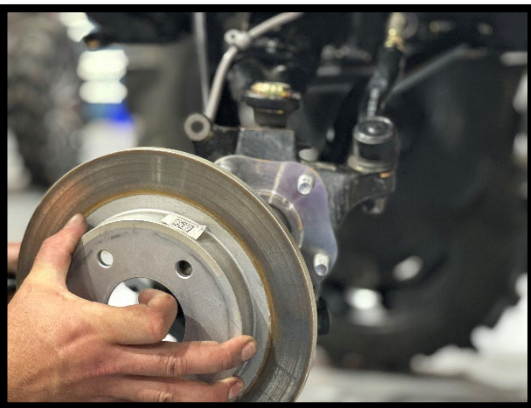

4

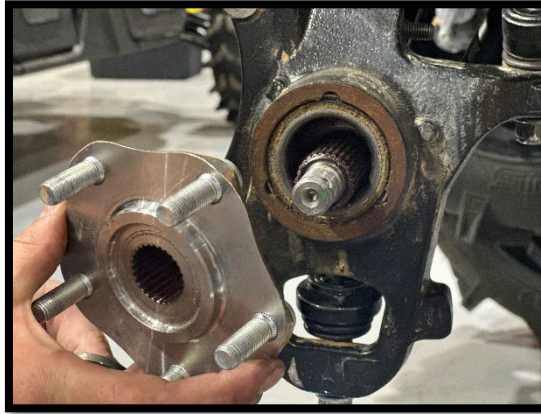

Remove the brake drum, cotter pin, axle nut, and washers from the hub assembly. **YOU WILL REUSE THE FACTORY HARDWARE** to reconnect the new control arms to the frame.

REMOVING STOCK COMPONENTS

Front End Prep

4 Before removing the upper and lower arms from the front hub assembly, you will first need to disconnect:

- A. Tie rod
- B. Lower Shock End
- C. Upper Ball Joint
- D. Lower Ball Joint
- E. Sway Bar Link



5 REMOVING STOCK COMPONENTS

Control Arms

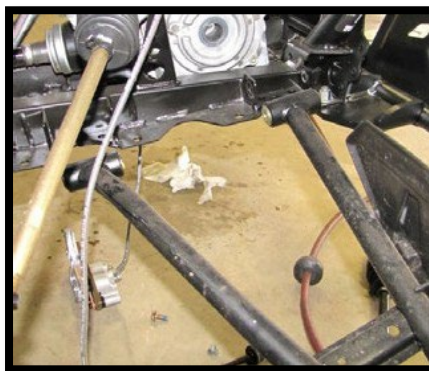

Remove the Lower Arm **FIRST** by removing the bolts at the knuckle and the frame. **KEEP ALL FACTORY HARDWARE.**

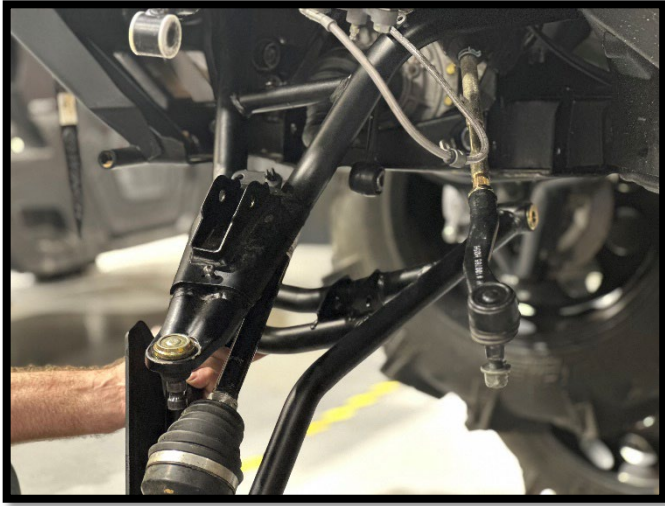

Disconnect the Upper arm by removing the bolts from the frame. **KEEP ALL FACTORY HARDWARE.**

BUSHINGS

Removal

6

IF YOU ORDERED PRE-INSTALLED ARMS SKIP TO STEP 10

IF YOU HAVE ACCESS TO A BLIND BEARING PULLER WE HIGHLY RECOMMEND USING THIS TOOL OVER THIS METHOD. USING A PUNCH MAY CAUSE DAMAGE TO THE BUSHINGS.

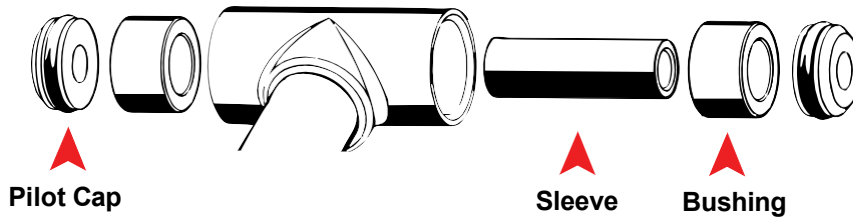

UPPER ARM



You will need to reuse your factory pivot caps, bushings, sleeves, and ball joints. Make sure that you inspect your bushings and ball joints for wear. Replace as needed.

Remove pivot caps and sleeves from both arms

Use a blind bearing puller or a flat punch to remove the bushings.

Use caution when removing the bushing from the collar, there is a stop built into the factory arm that prevents the bushing from pushing out when installed. Because of this, the bushing must be pushed out from the opposite side.

7

LOWER ARM

Once the bushing is inserted, you will need to use a socket, of the same diameter as the bushing, to help press it in all the way.

Applying grease to the bushings and sleeves will make the installation easier.

Use a press or vice to secure the bushings.

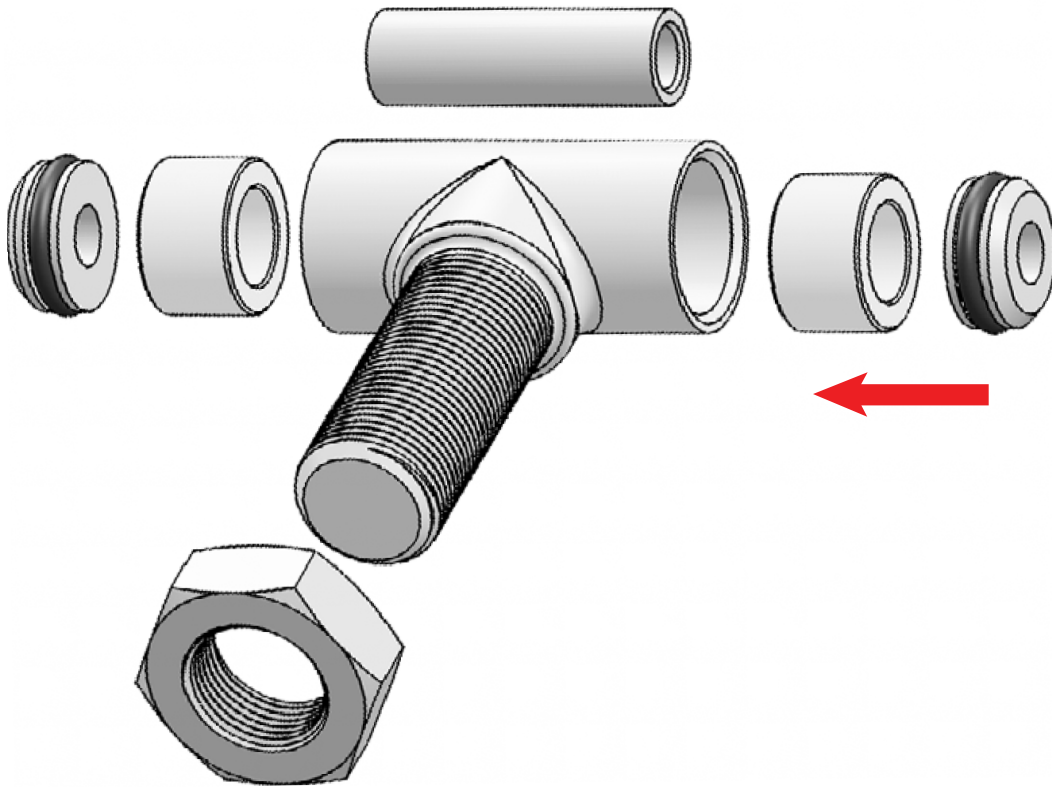

8

IF YOU HAVE PRE-INSTALLED BALL JOINTS SKIP TO STEP 10

NOTE: FOR DEMONSTRATIVE PURPOSES WE USED THE LOWER CONTROL ARM, BUT THE PROCESS IS SIMILAR FOR BOTH. A press or a vise is suggested for removing and replacing the ball joints.

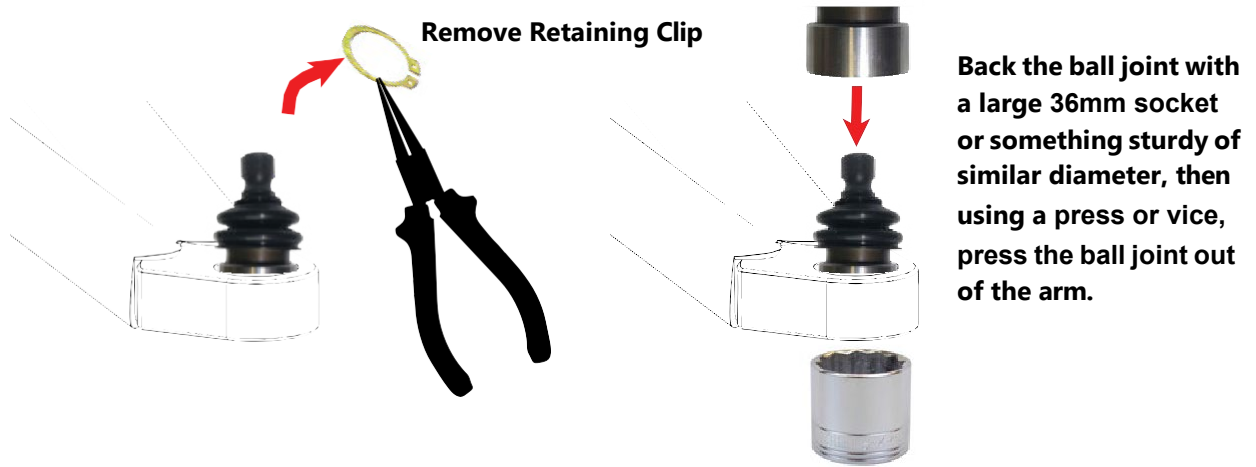

9

Flip the control arm over, and using the same process, press the ball joint in using a vice or press. If you press in the ball joint crooked, DO NOT TRY TO FORCE IT IN! If you try to force it straight you can "egg" the opening. Press the ball joint out and reinsert it into the opening, pressing it in with a vise. Verify that the clip snaps into place after installing the ball joints into the new Control Arm. You should always double check the ball joint snap ring for proper fit. Even if you use snap ring pliers, it may not seat. You can use a flathead screwdriver and a hammer to tap the snap ring to ensure that it is seated into the groove.

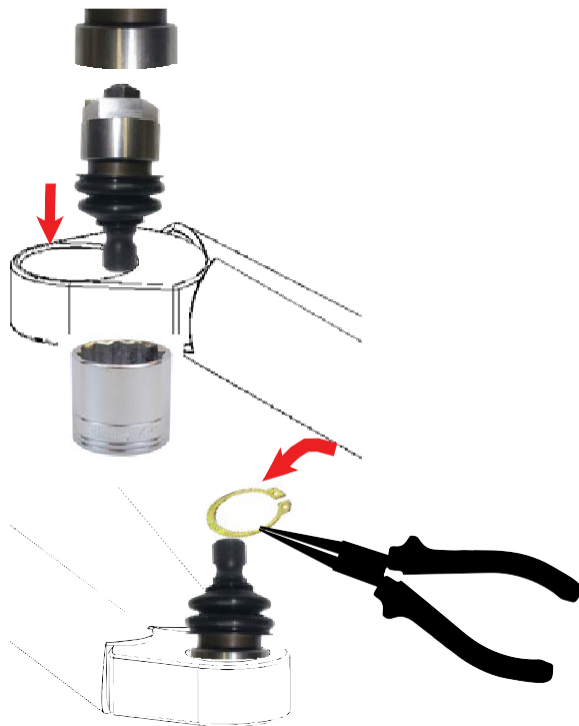

BALL JOINT ORIENTATION



Snap the retaining clip down on to the base of the ball joint.

10

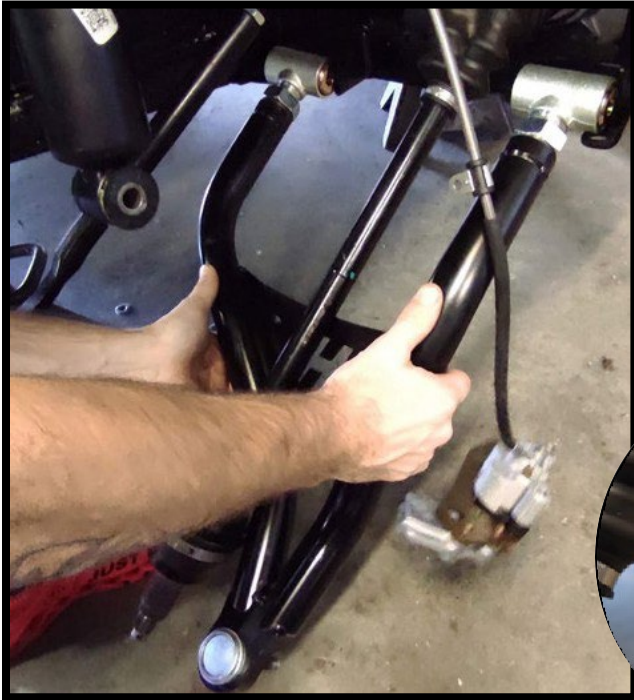

Connect the hub at the LOWER pinch bolt FIRST, then slide the axle through AFTER. DO NOT FORGET WASHERS.

Connect the new lower arm at the frame using the factory hardware. **NOTE: MAKE SURE BRAKE LINE IS ROUTED OUTSIDE THE LOWER ARM TO THE FRONT OF THE UTV.**

11

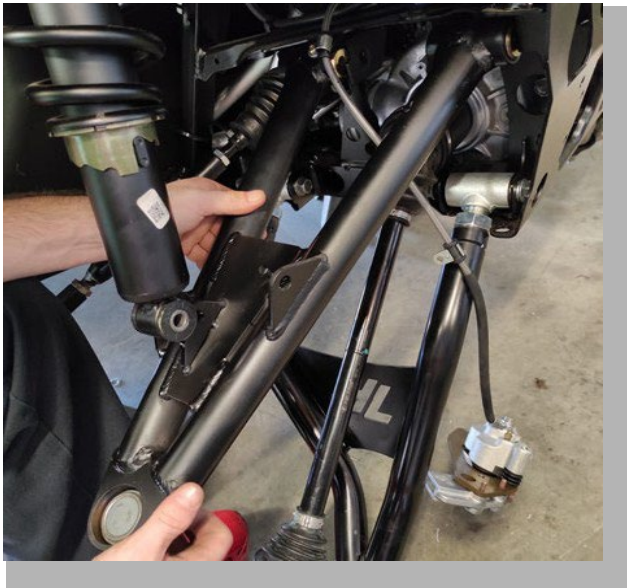

Using factory hardware, connect the new upper arm to the frame, the pinch bolt on the knuckle, and sway bar if your model has one. Connect the lower shock tab LAST.

NOTE: MAKE SURE THAT THE BRAKE LINE IS ROUTED THROUGH THE UPPER ARM LIKE FEATURED IN THE PHOTO.

12

Reattach the rotor to the knuckle assembly. Install washers and secure using the castle nut and cotter pin.

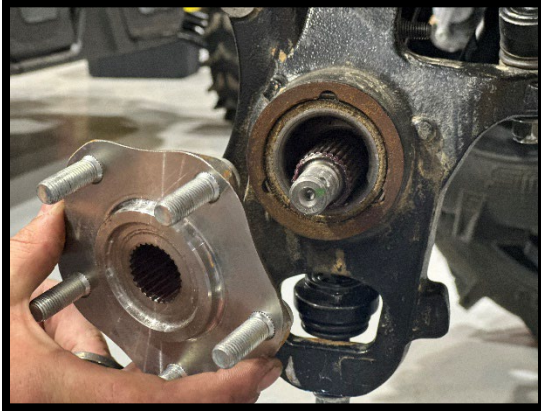

13



Connect the caliper to the hub assembly. Make sure that you re-route the brake lines, so that they do not come in contact with moving parts and don't become pinched. Connect the brake line clamp to the arm using the brake line clamps provided in the kit.

REPEAT STEPS FOR OPPOSITE SIDE

15

NOTICE: DO NOT remove the pinion. The images featured are for DEMONSTRATIVE PURPOSES ONLY.

BOOT REMOVAL

The rubber boots on the rack and pinion are held on by zip ties. You will need to cut the zip tie that secures the boots to the inside of the rack and pinion.

START WITH THE DRIVER'S SIDE

This side has the least amount of room. Once you install the spacer on the passenger side you will have less play on the driver's side. **DO NOT REMOVE THE FACTORY SPACER ALREADY IN PLACE.** Turn the steering wheel all the way to the **RIGHT**.

PASSENGER SIDE

Turn the steering all the way to the left. Place the steering stop (10U) between the inner tie rod joint and the rack and pinion. It is a tight fit, so you may have to force it on, this is to ensure that the spacer stays in place.

RESECURING BOOT

you will need to turn the steering wheel closer to the center to allow play in the boot. Slide the boot back down and secure it with an 8" zip tie.

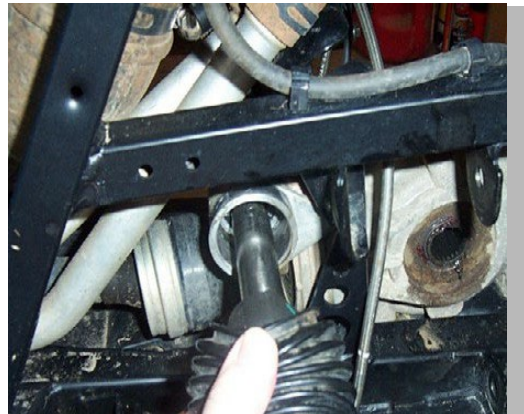

16

IF YOU HAVE ADJUSTABLE CONTROL ARMS, YOU MUST ADJUST THE CAMBER FIRST BEFORE PROCEEDING. DO NOT INSTALL WHEELS ONTO UTV UNTIL PROPER ALIGNMENT HAS BEEN ACHIEVED.

- Straighten steering wheel
- Make sure that the brake rotors are straight to sight or level.
- Take a tape measure and measure from inside to inside on the front and back ends of the rotors.

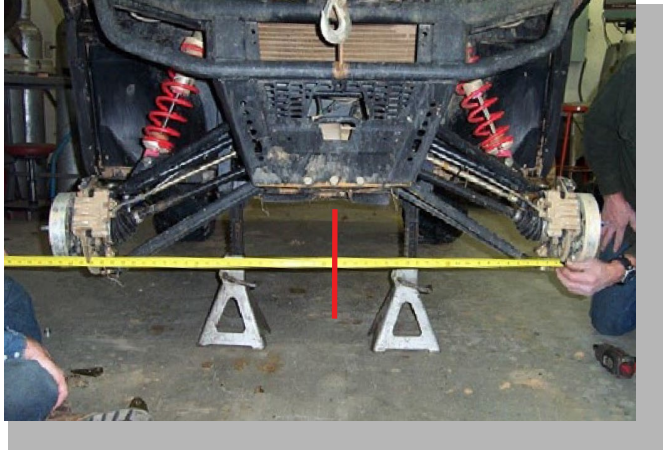

INCORRECT TOE

If the toe alignment is incorrect, measure the distance between vehicle center and each wheel. This will indicate which tie rod needs adjustment.

ADJUSTING TOE

- Adjust tie rods until BOTH measurements are the SAME, then adjust toe tolerance.

The recommended vehicle toe tolerance is 1/8" to 1/4" (3.175-6.35mm) toe out. This means the FRONT MEASUREMENT IS WIDER THAN THE REAR MEASUREMENT.

TOE ADJUSTMENT CHART

| | | | | | | |
|---------------|-------|-------|-------|-------|-------|-------|
| TOE (Inches) | 1/16 | 1/8 | 3/16 | 1/4 | 5/16 | 3/8 |
| TOE (Degrees) | 0.12° | 0.25° | 0.38° | 0.51° | 0.64° | 0.76° |

Recommended Settings



If the FRONT OF THE WHEELS are facing OUT, adjust the tie rods OUT or INCREASE the length of the tie rod.

Measurement at the front of the tires will be GREATER than the rear, if the TOE IS OUT.



If the FRONT OF THE WHEELS are facing IN, adjust the tie rods IN or REDUCE the length of the tie rod.

Measurement at the front of the tires will be LESS than the rear, if the TOE IS IN.



IMPORTANT NOTE: When tightening the tie rod jam nuts, the tie rod ends must be held parallel to prevent rod end damage and premature wear. Damage may not be immediately apparent if done incorrectly. After alignment is complete, tighten & torque tie rod end jam nuts to specifications. [12-14 ft lbs]

17 **BEFORE STARTING** 

- Tires must be off the ground
- Tires must have equal air pressure
- Suspension components must be completely assembled

The new High Lifter lower control arms will come pre-adjusted to factory length, which is .937. If you need to re-adjust the collars, place the factory arm and new control arm on a flat surface. Measure from eyelet to center mount on the factory arm, and then adjust the new arms to those lengths.

NOTE: When re-adjusting, leave the jam nuts loose. Do not fasten tight until installed on UTV, after all final adjustments have been made.

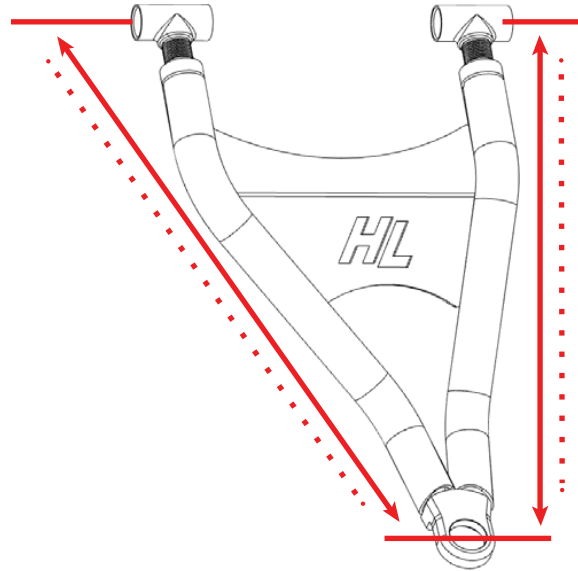

Positive Camber

If you have a positive camber you will need to adjust the collar **OUTWARD** or lengthen the control arm. The maximum amount outward is "1.250" which could give up to 3° of positive camber.



Correct Camber

For this application, we recommend a camber setting of 0°. Collars are preset to .937



Negative Camber

If you have a negative camber you will need to adjust the collar **INWARD** or shorten the control arm. The maximum amount inward is zero threads exposed and could give over 3° of negative camber.



Make all adjustments in small increments.

Do this by disconnecting control arms at the frame and adjusting collars. Once small adjustments have been made. Take the UTV off the jack and roll it back and forth several times to check the camber. Repeat steps as needed. After alignment is complete, tighten jam nuts to 80 ft-lbs and secure it with blue loctite.



HIGH LIFTER LIMITED LIFETIME WARRANTY

High Lifter offers a Limited Lifetime Warranty to the original purchaser that our product shall be free from defects in material and workmanship for the life of the product if utilized in accordance with the manufacturer's instructions for installation and operation of said products.

LIMITED LIFETIME WARRANTY EXTENDS TO THE FOLLOWING PRODUCT LINES:

- Lift Kits (Signature, Standard and Big Lifts)
- Control Arms
- Trailing Arms
- Radiator Relocation Kits
- Portal Gear Lifts
- Wheel Spacers
- Tow Hooks
- Control Arm Link Kits

Damages to vehicle or any other object during the installation, use, or removal of High Lifter products are not covered under this warranty. Normal wear items included with any of the products covered under this Limited Lifetime Warranty are excluded from coverage. These items include, but are not limited to heim joints, tie rods, bearings, bushings, seals, gaskets, zinc plating, painted and powder coated finishes. Other exclusions of coverage under this warranty include, but are not limited to: damage or product failure due to improper installation, lack of maintenance, product modification, abuse, collision or use on vehicles for which product was not designed, repairs performed by anyone other than approved High Lifter personnel or made using non-High Lifter components. This warranty is valid for the original purchaser only and is non-transferable. High Lifter reserves the right to inspect any product before determining if the claim is valid and covered under this warranty. Claims determined to be caused by reasons other than a manufacturer defect will be rejected and an estimate for repair or cost of a replacement product if a repair is not possible, will be provided.

This warranty is exclusive and is in lieu of any implied warranty of merchantability, fitness for a particular purpose or other warranty of quality, whether express or implied, except the warranty of title.

WARRANTY PROCESSING

If you suspect your product is defective, DO NOT disassemble the product to determine the cause without prior approval as it may void your warranty status. This is especially true with our Portal Gear Lift. To begin the claim process, please e-mail our warranty team at warranty@highlifter.com and include the following in the e-mail:

- Your full name, address and contact phone number.
- The year, make and model of your vehicle
- The part number of the product
- Photos of the product installed, and vehicle product is installed on
- Proof of Purchase (Required for all warranty claims and you must be the original purchaser)

Once a claim is created, you will receive a return authorization number (RMA). Write this number on the outside of the box containing your defective product and include it along with your name and contact information inside the box. Product must be returned in the original box or a box of equal strength and packaging. Product sent without an RMA number visible on the outside of the box or sent COD will be refused. Ship your product to the following address:

High Lifter Products, Inc.
Attn: Returns 7455 Atkinson Dr, Shreveport, LA 71129

Once your product is received, we often have your replacement or repaired product shipped back to you within 3-business days of receiving it. Please note that High Lifter is not responsible for shipping charges on product returned for warranty or repair, including duties and fees required by those residing outside the United States.